

# Specifications

## POWER INPUT

- 200, 220 or 240 VAC (jumper selectable) 50/60 Hz
- 1500 VA max

## TRIGGERING

Standard

Pulse Source: +2.5 V pk min, ≥ 100 microseconds pulse

- Current Sink: ≥ 12 VDC @ 10 mA rating
- Video: 1 V p-p nominal unterminated. Trigger from 30 Hz frame rate or 60 Hz field rate

Optional

Analog proportional line speed input for synchronizing flash rate to line speed (0-10 VDC or 4-20 mA, requires SILC Deluxe Remote Control)

Manual Mode

- 30 Flashes/Minute (F/M) to 6,000 F/M (12,000 F/M Optional)
- Automatically limits H8D light head maximum flash rate options (6,000 F/M, 12,000 F/M)
- 1 F/M resolution
- 100ppm/°C accuracy

## TRIGGER SUPPLY

- Regulated 12 VDC current limited @ 100 mA, available at "Trigger In" connector
- Designed to meet SELV requirements of VDE 0805 and IEC 950 Safety Specifications

## TRIGGER OUTPUT

- Open collector signal to synchronize the driving of a second unit. Available at the "Sync Out" connector

## REMOTE CONTROL SUPPLY

- 12 VDC current limited @ 500 mA for controller unit. Available at the "Remote Connector"
- Designed to meet SELV requirements of VDE 0805 and IEC 950 Safety Specifications

## ENERGY OUTPUT

- (Standard) 4 joules per flash @ 6,000 F/M
- (Optional) 2 joules per flash @ 12,000 F/M

Lamp

- Xenon gas type, plug-in assembly

Lamp Output

- 2200 Lux (200 foot candles) at 1.5 meters (60 in) 100% intensity at maximum flash rate

## FLASH DURATION

- 10 microseconds

## PHYSICAL

Light Head with Yoke

- 375mm (14.75 in) X 406mm (16 in) X 203mm (8 in) Weight: 9 kg (20 lb)

Power Supply

- 406mm (16 in) X 533mm (21 in) X 239mm (9.4 in) Weight: 32 kg (70 lb)

Environmental

- Continuous operating temperature range 0-50°C (32-122 °F)

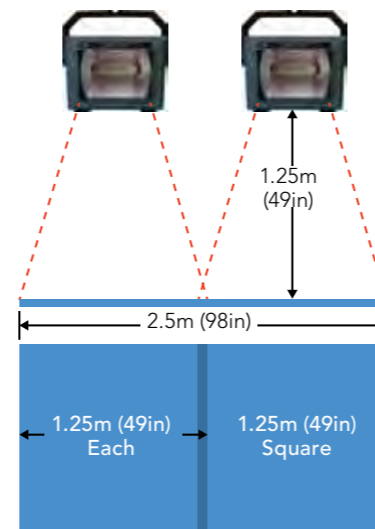

Larger areas can be illuminated by moving the light head further from the strip surface.

# SENTRY

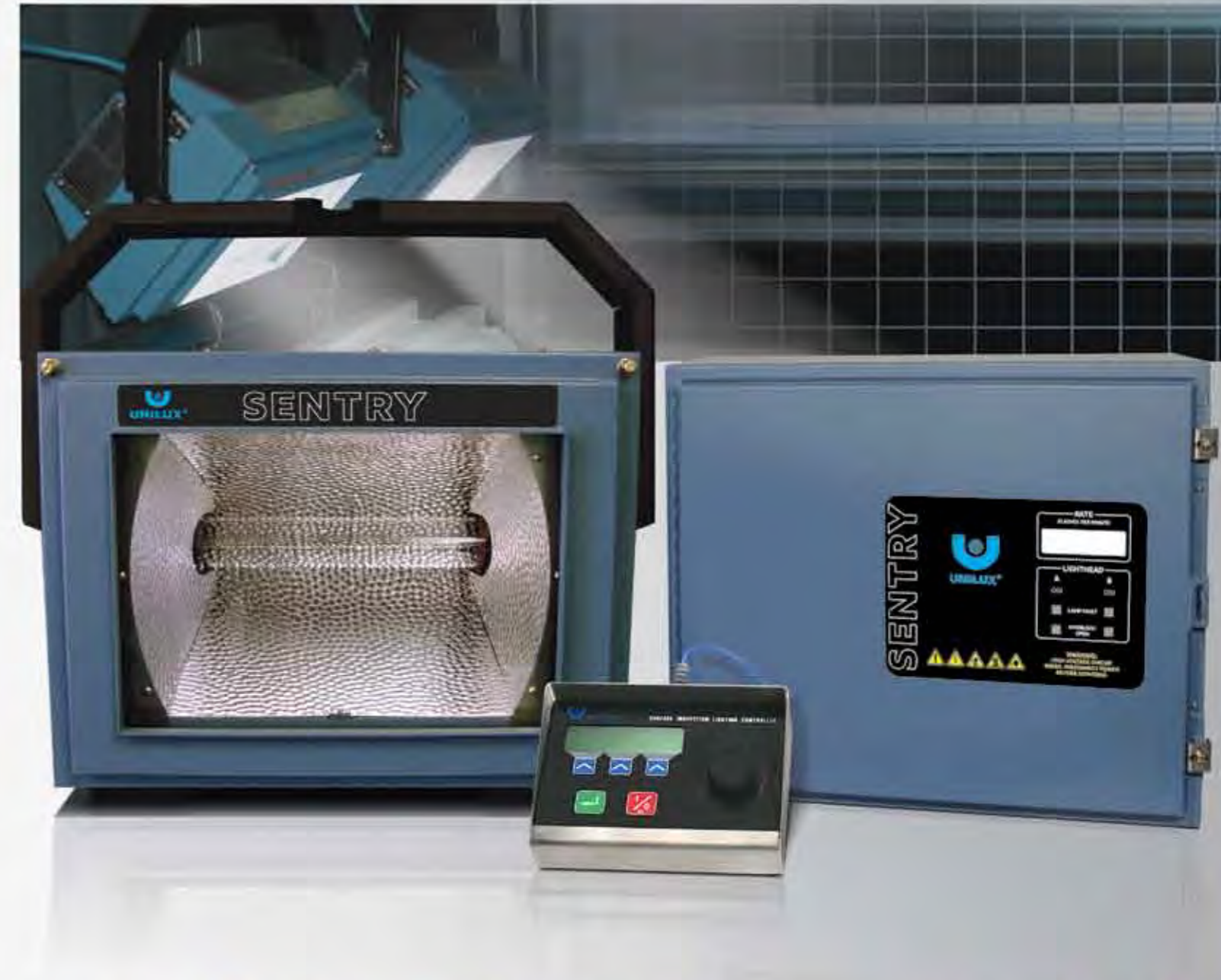

Other Unilux products for the steel industry include:



# SENTRY

The Sentry is an industrial stroboscopic lighting system developed to improve and protect product quality by supplying advanced clarity and definition of surface imperfections at full production speed. Random and repetitive defects such as scratches, dents, roll marks, bruises, edge cracks, and coating voids can be identified immediately, allowing operators to take corrective action, eliminate further mistakes, reduce unnecessary waste, and prevent customer rejection. The Sentry's high-intensity pulsed lighting "freezes" the surface texture which makes identifying flaws and irregularities possible, even while traveling

at speeds up to 2,300 meters per minute. Available with one light head or two, the Sentry evenly illuminates strip widths up to 2.6 meters (102 inches) from a 1.5 meter (60 inch) distance from the surface.

## The Sentry Advantage

- Immediate knowledge of production defects
- Complete strip illumination
- High intensity with even illumination
- Quick release adjustable light head
- Small light head(s) fit into tighter areas

## Key Features

- Synchronizes to line speed for inspection efficiency
- Adjustable light intensity
- Modular electronic and wiring components
- Quick change snap-in lamp requires no tools
- Interconnecting cables allow multiple units to operate off of one another
- Available in one light head or two for maximum coverage
- Press-to-test system analysis switch

## Applications

**METALS:** Cold reduction, temper mills, skin pass lines, tin plate, electrolytic galv, hot dip galv, leveling, coating, pickling

**PRINTING:** Film and foil, slitter, rewinder

**CONVERTING:** Slitter, rewinder, coating

# Accessories

## Articulating Arm

With a reach of 1.2m (48in), the Articulating Arm is suited for mounting flexibility. Carbon steel construction with friction adjustments eliminate free swing.

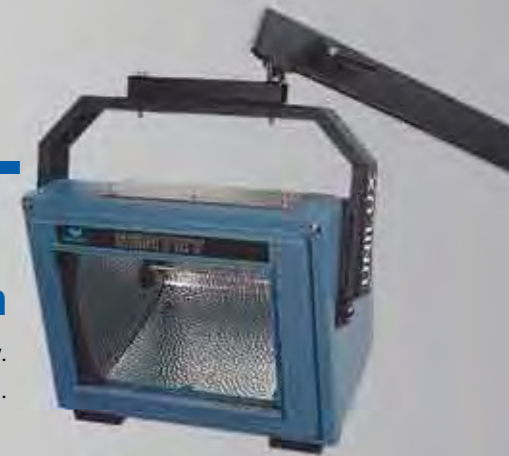

## Proportional Line Speed Option

The Analog Line Speed Kit processes the synchronization signal used to keep the H8D light heads in sync with the mill. A 0 ~ 10VDC or 4 ~ 20mA signal is used to ensure everything is timed perfectly.



## Rotary Encoder

For automatic web synchronization, the Rotary Encoder, with its soft rubber wheel, is designed to ride on the web material or roller to follow the speed of the web.

# Remote Control Options

## Basic Remote Control

The Basic Remote Control features full control settings for power, intensity, flash rate and internal and external triggering.

Features:

- Remote on/off switch
- Four light intensity levels
- Switch between internal or external triggers
- Set up for automatic line synchronization available in printing applications when used with rotary encoder



## Deluxe Remote Control

The Surface Inspection Lighting Controller (SILC) features full menu control of all functions and automatic tracking with pre-set storage. A two-line digital character display simplifies operation and supplies line speed information.

Features:

- Adjustable intensity (30 - 100%)
- Auto sync to line speed
- Metric or English options
- Sealed membrane switches
- Controls multiple light heads
- 0-10 volts or 4-20 mA
- Easy set-up menu



**100% strip inspection at full production speed**

**Automatic tracking to line speed**

**Remote control options**

**Heavy duty construction**

